

## Stress Calibration for Jitter >1UI – A Practical Method

Guy Foster  
SyntheSys Research, Inc.  
March 2010  
SR-TN092

### Abstract

While measuring the amount of jitter present on a signal is relatively straight forward conceptually when the levels of jitter are small, amounts above a bit period (1 unit interval or UI) can be more difficult. This has practical consequences for standards such as USB 3.0 where calibration at the test device of 2 UI at 500 kHz of sinusoidal jitter is required. This note describes use of patterns and triggering on a BERTScope to allow such calibration.

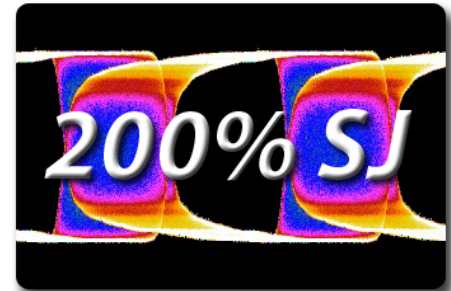

### Introduction

Most methods for measuring jitter based on sampling scopes and BERTs require there to be less than 1 UI of eye closure to function. This presents a problem for stressed eye receiver testing for standards such as USB 3.0 where it is mandated that the applied stress be calibrated at the device under test (DUT) rather than at the instrument front panel. For example, it is required that sinusoidal jitter of 2 UI be applied at 500 kHz modulation frequency.

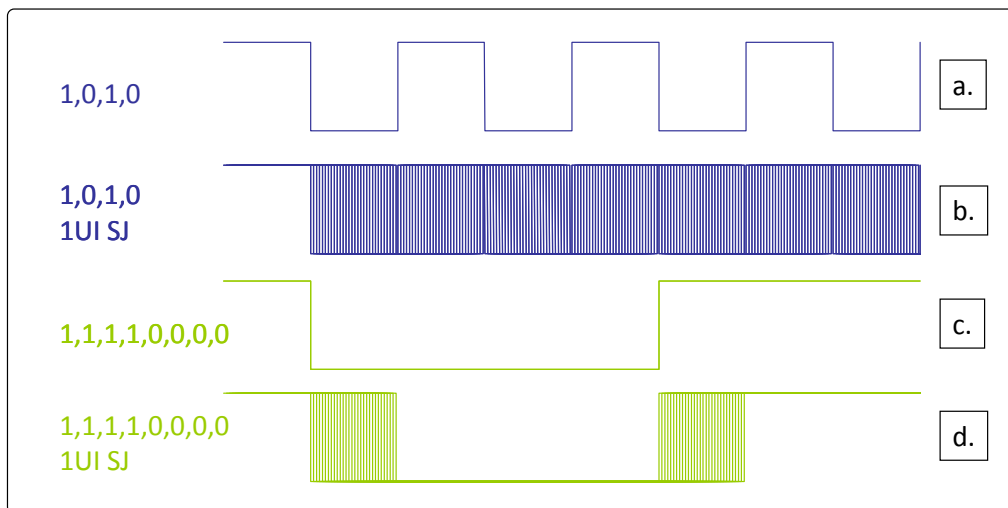

Figure 1 Applying 1 unit interval of sinusoidal jitter to two different patterns at the same data rate.

To illustrate the issue, Figure 1(a) shows a continuous one/zero pattern. When 1 UI of sinusoidal jitter is applied, it might look something like Figure 1(b). For jitter measurement methodologies that require at least some eye opening to function, it is clear why they would struggle. However, for situations such as stressed eye calibration where we have control of the pattern, Figure 1(c) and (d) suggest a way forward. If the pattern is changed to 4 ones, 4 zeroes, that same amount of jitter is not causing complete eye closure, and therefore can be measured. The trick is to cause the jitter measuring instrument to believe that the unit interval is now four times longer; this can be accomplished by triggering the analyzer with a divided clock.

## Measured Example

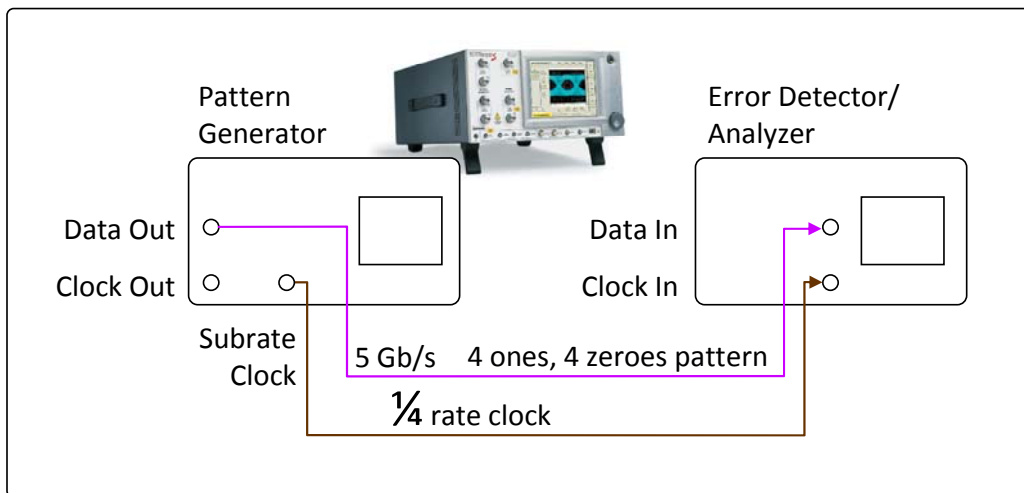

Figure 2 Test setup for measuring 2UI of sinusoidal jitter.

A generic setup is shown in Figure 2; this methodology is not specific to the BERTScope. For our measured example, the 4 ones/4 zeroes pattern is being sent by the pattern generator to the analyzer, along with a divided clock. The generator was set to 5 Gb/s, and around 2 UI of sinusoidal jitter applied. The analyzer received the clock at 1.25 GHz and the measurements were executed using the 1.25 GHz bit period of 800 ps as the unit interval, as shown in Figure 3 and 4. (The measurement setup had a filter and short length of ISI in the measurement path, which are not shown in Figure 2.)

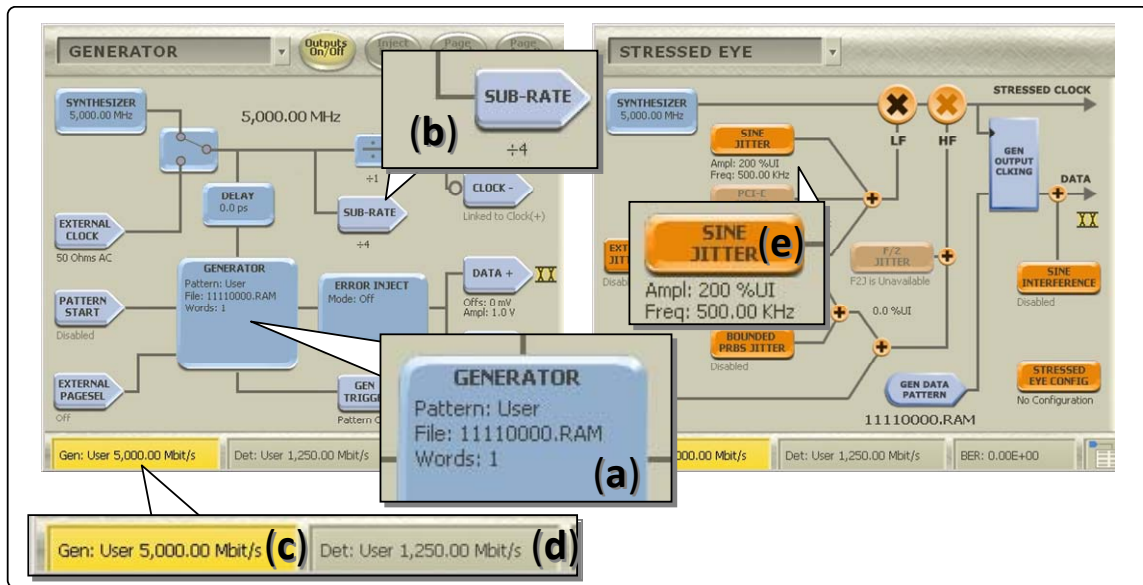

Figure 3 The Pattern Generator (PG) setup showing the 4 ones/4 zeroes pattern loaded (a), the divided clock output (b), the data rate of 5 Gb/s (c) and the received clock rate of 1.25GHz (d). Some of the subsequent screenshots have 2UI of SJ applied as shown on the stress setup screen (e).

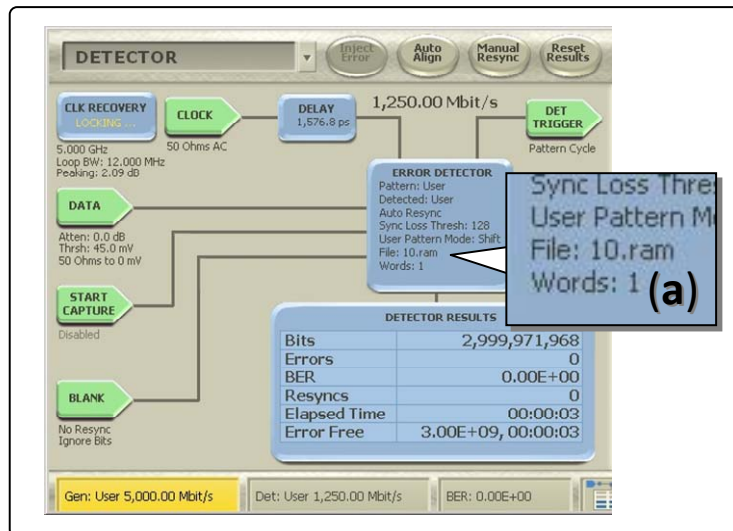

Figure 4 The Error Detector (ED) showing the one/zero pattern loaded (a)

## Measured Results

The unstressed eye diagram is shown in Figure 5(a). The effects of the filter and ISI are visible in the rounded edges, but are not relevant to understanding this example. 5(b) shows the same eye diagram with sinusoidal jitter added. Remember that the applied level is 2 UI, significantly beyond the measurement range of dual-Dirac-based measurement in normal use. Figure 5(c) shows a Jitter Peak measurement of Total Jitter (TJ). As expected, the measurement is dominated by Deterministic Jitter (DJ).

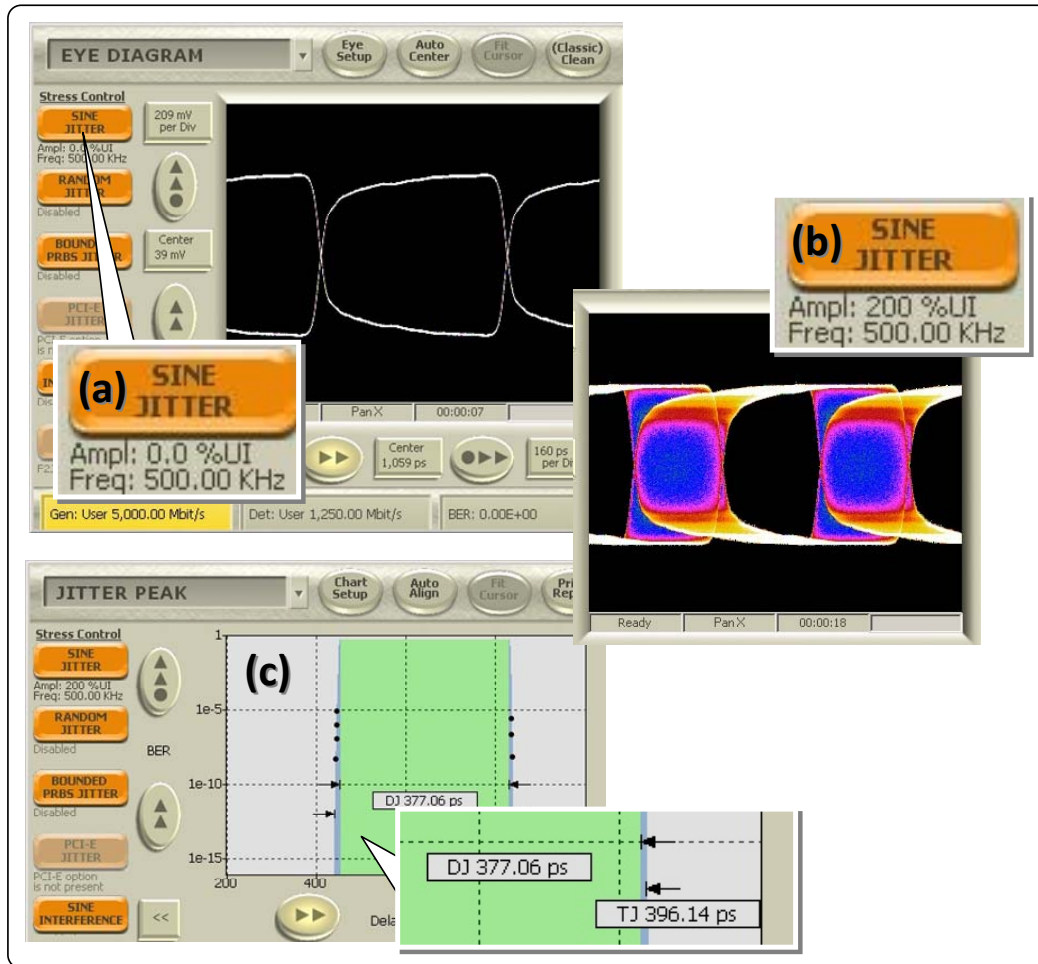

Figure 5 Measured results showing an eye diagram with no jitter applied (a), 2UI of jitter applied (b) and a successful measurement of TJ (c).

## Limitations

This methodology lends itself to a situation such as stressed eye calibration where the user has control over the pattern. Obviously it is also only useful for sources of applied jitter that are pattern-length independent. The approach can be extended to patterns containing longer runs of ones and zeros, but this necessitates a higher divide ratio; for high speed instruments such as sampling scopes and BERTs, care must be taken to make sure the incoming clock rate doesn't go below the lowest operating rate of the analyzer, or that measurement times don't become inconveniently slow.

---

## Reference

---

For jitter tolerance testing requirements of USB 3.0, refer to “USB 3.0 Receiver Compliance Testing” by Cynthia Nakatani, January 2010, [www.bertscope.com](http://www.bertscope.com).